

## NOVUX™ Fiber Optic System CC 40 Basic Instructions

### About this manual

This manual describes the basic installation steps of the Compact Closure 40. The document starts with providing an overview of the tools required to perform the installation. Also warnings and cautions are indicated, which should be observed before starting the product installation.

Installation steps in this document are limited to: closure preparation, organizer preparation, feeder cable preparation and installation, closing the closure and mounting the closure. For the installation steps required for the splice application (front side), refer to TC-1520-IP-SP: CC 40 Splice application. For the installation steps required for the patch application, refer to TC-1520-IP-PA: CC 40 Patch application.

Images in this manual are for reference only and are subject to change.

### General product information

#### Dimensions

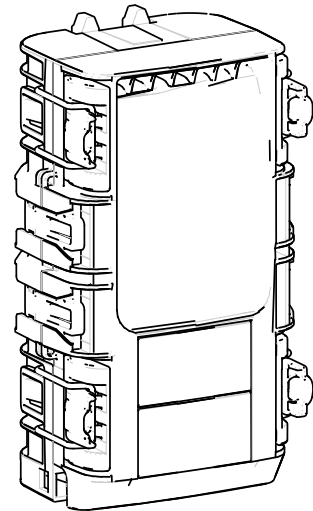
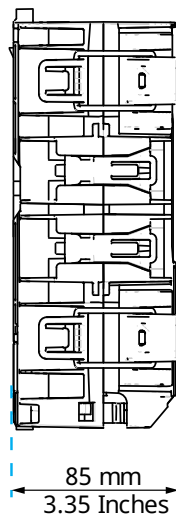
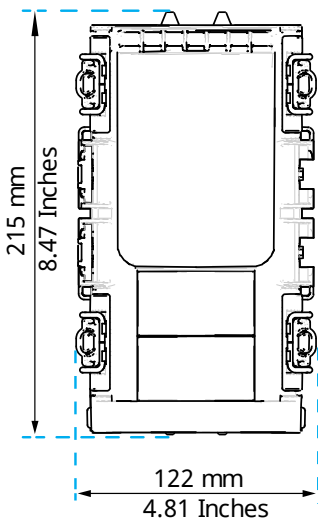

#### Cable diameter range

Position	Cable diameter	
	mm	Inches
Feeder cable	≤ 14	≤ 0.55
Single drops	≤ 6,2	≤ 0.25
Dual drops	≤ 6,2	≤ 0.25
Air blown fiber	< 8	< 0.32

## Overview organizer rear side

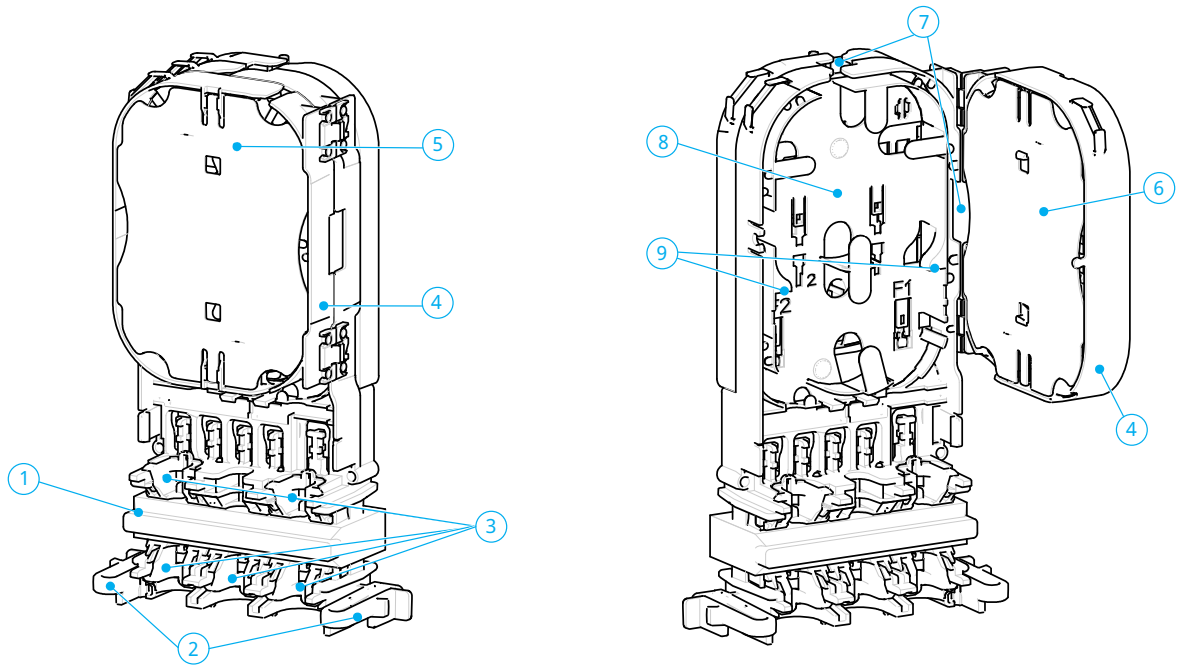

- 1 Octopus™ gel seal
- 2 Snap features
- 3 Port reducers
- 4 Hinged tray
- 5 Front cover hinged tray
- 6 Back cover hinged tray
- 7 Transportation zones subunits
- 8 Loop storage basket
- 9 Connection points for feeder bracket

# Contents

<b>1 Abbreviations.....</b>	<b>4</b>	8.1 Using the feeder strain relief bracket.....	9
<b>2 Tools.....</b>	<b>4</b>	8.2 Using the cable retention NVX-CR-DU-SL-NN: Mini dual cable.....	12
<b>3 Warnings and Cautions.....</b>	<b>4</b>	8.3 Route feeder fibers to storage.....	12
<b>4 Kit contents.....</b>	<b>5</b>	<b>9 Re-install organizer.....</b>	<b>14</b>
<b>5 Closure preparation.....</b>	<b>5</b>	9.1 Re-install organizer.....	14
5.1 Open the latches.....	5	<b>10 Close the closure.....</b>	<b>15</b>
5.2 Install the hinges in another position.....	5	<b>11 Mount the closure.....</b>	<b>15</b>
5.3 Access the inside of the closure.....	7	11.1 Using the Mobra.....	15
<b>6 Remove fiber organizer.....</b>	<b>7</b>	11.2 Using the mounting tabs.....	17
<b>7 Install the Octopus™ gel blocks.....</b>	<b>8</b>	<b>12 Disclaimer.....</b>	<b>19</b>
<b>8 Feeder cable.....</b>	<b>9</b>	<b>13 Contact information.....</b>	<b>19</b>

# 1 Abbreviations

CC: Compact Closure

Mobra: Mounting bracket

# 2 Tools

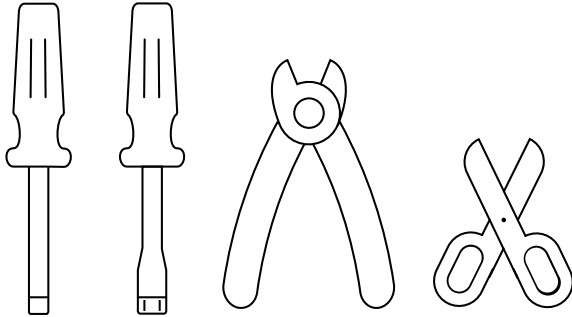

- Flat screw driver
- Socket wrench
- Small side cutter
- Scissors

# 3 Warnings and Cautions

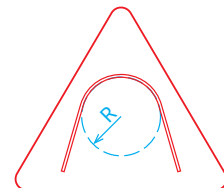
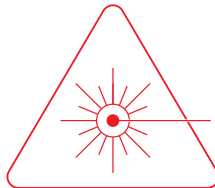
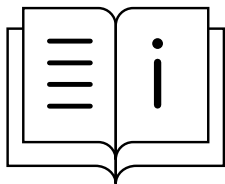

- Follow the installation instruction steps to ensure the performance of the closure. It is necessary to take precautions and keep the working space clean to protect the closure sealing materials and splices.
- Exposure to laser radiation can seriously damage the retina of the eye. Do not look into the ends of any optical fiber. Do not assume the laser power is turned off or that the fiber is disconnected at the other end. Looking into the ends of any optical fiber is entirely at your own risk. A protective cap or hood **MUST** be immediately placed over any radiating adapter or optical fiber connector to avoid the potential of dangerous amounts of radiation exposure. This practice also prevents dirt particles from entering the connector and adapter.
- Fiber optic cables may be damaged if bent or curved to a radius that is less than the recommended minimum bend radius. Always observe the recommended bend radius limit when installing fiber optic cables, subunits and patch cords.

## 4 Kit contents

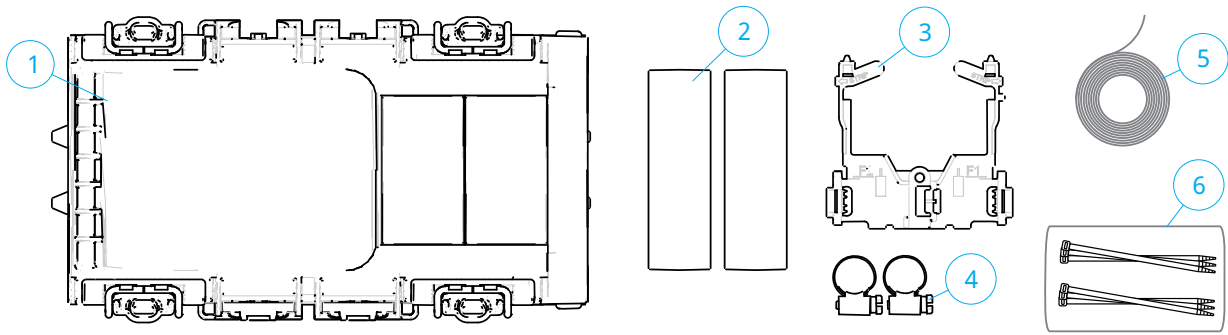

N°	Description	Qty
1	Closure with organizer	1
2	Octopus™ gel blocks	2
3	Feeder strain relief bracket	1
4	Hose clamps	2
5	Silicone tape 1,25 cm / 0.5 Inches width	1
6	Cable ties	2x6

 **Note:** Contents can vary depending on the configuration.

## 5 Closure preparation

### 5.1 Open the latches

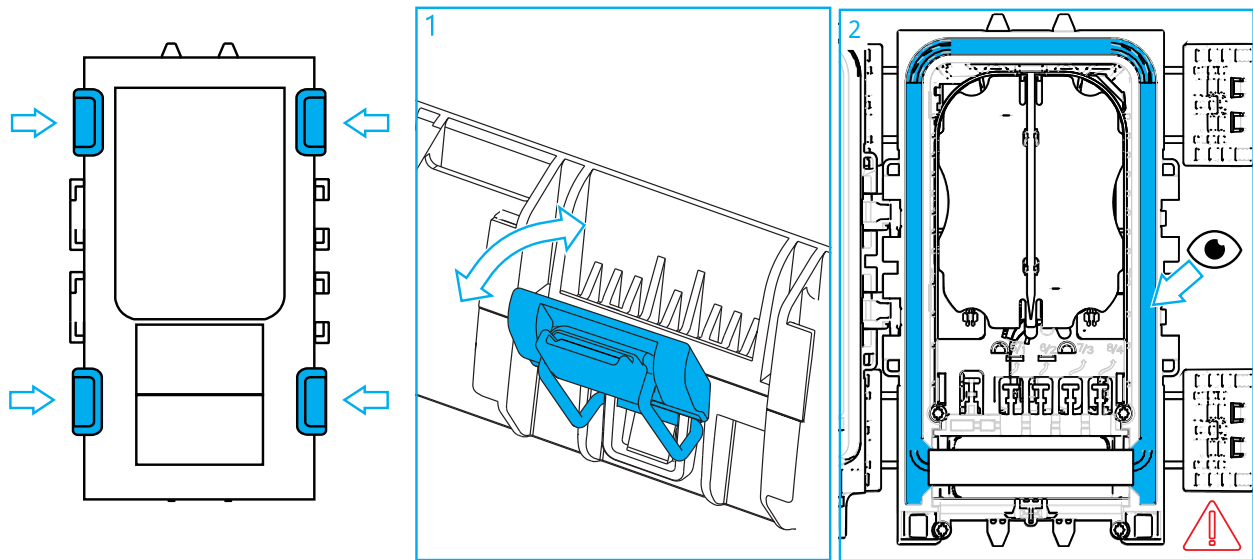

- 1 To open the closure, open the latches.
- 2 Rotate the cover. Verify the long seal remains correctly seated within the closure cavity.

### 5.2 Install the hinges in another position

The hinges are pre-installed on the left side. However it is possible to install them in another position. First the hinges should be removed.

## 5.2.1 Remove the hinges

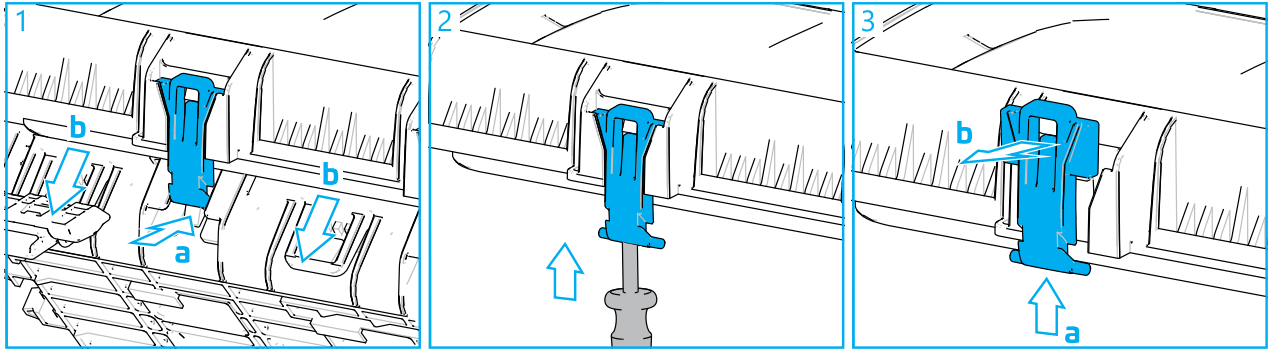

- 1 Remove the cover from the base.
  - a Push on the snap features under the hinge on the base.
  - b Slide the cover with the hinges over the snap features.
- 2 Use a screw driver to disassemble the hinges from the cover.
- 3 Lift the hinges up and then remove.

## 5.2.2 Re-install the hinges

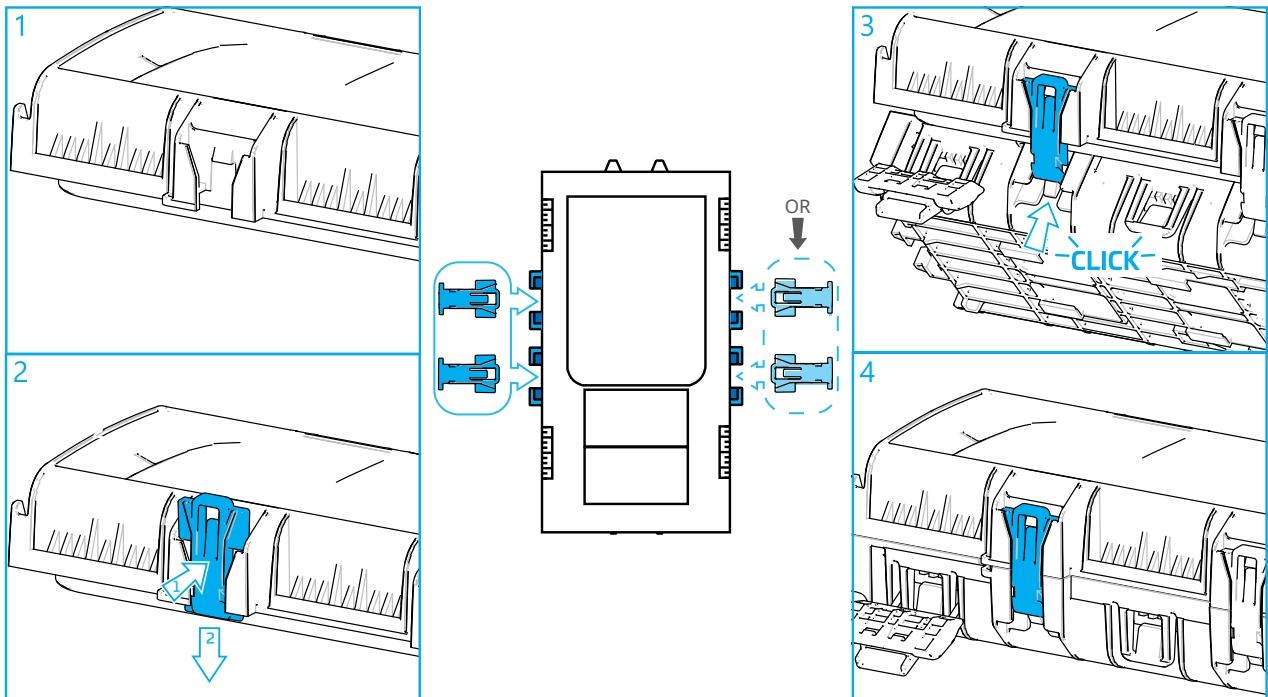

The hinges can be installed on the left or right of the cover.

- 1 Slide the hinge into the openings of the cover.
- 2 Then slide the hinge down in its lock position.
- 3 Assemble the cover and base by sliding the cover hinges into the cavities within the base. The hinges are properly seated in the base if a clicking sound is noticed.
- 4 Rotate the cover towards the base and close the cover.

### 5.3 Access the inside of the closure

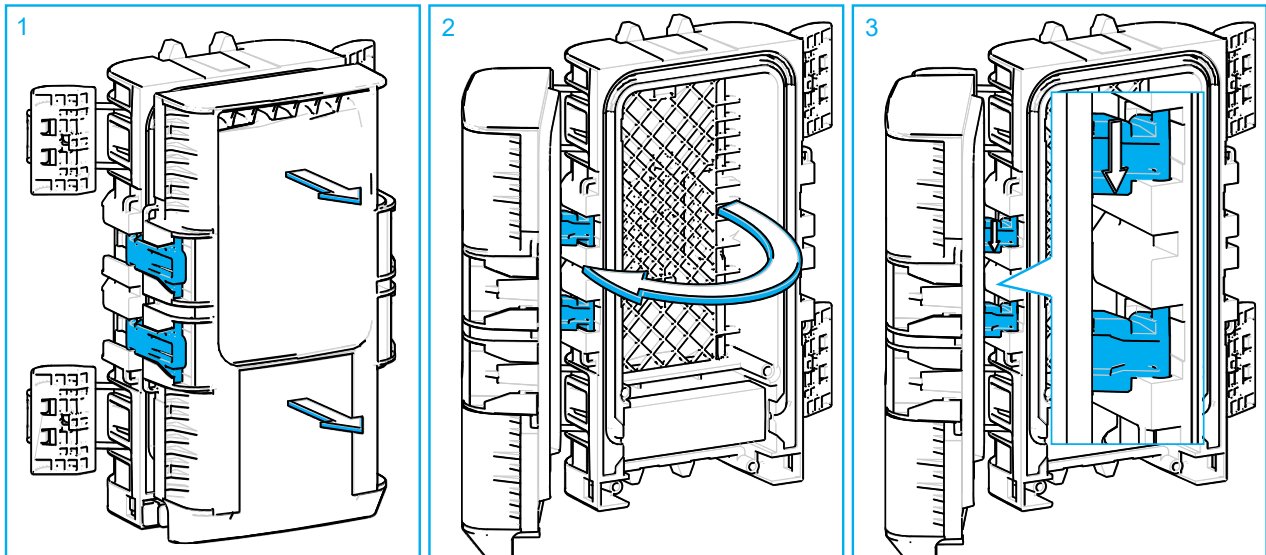

- 1 Open the closure, lift the cover up.
- 2 Hinge the cover open to the side of the installed hinge.
- 3 Secure the cover in open position: the cover with hinges will move downwards and will lock into the base.

### 6 Remove fiber organizer

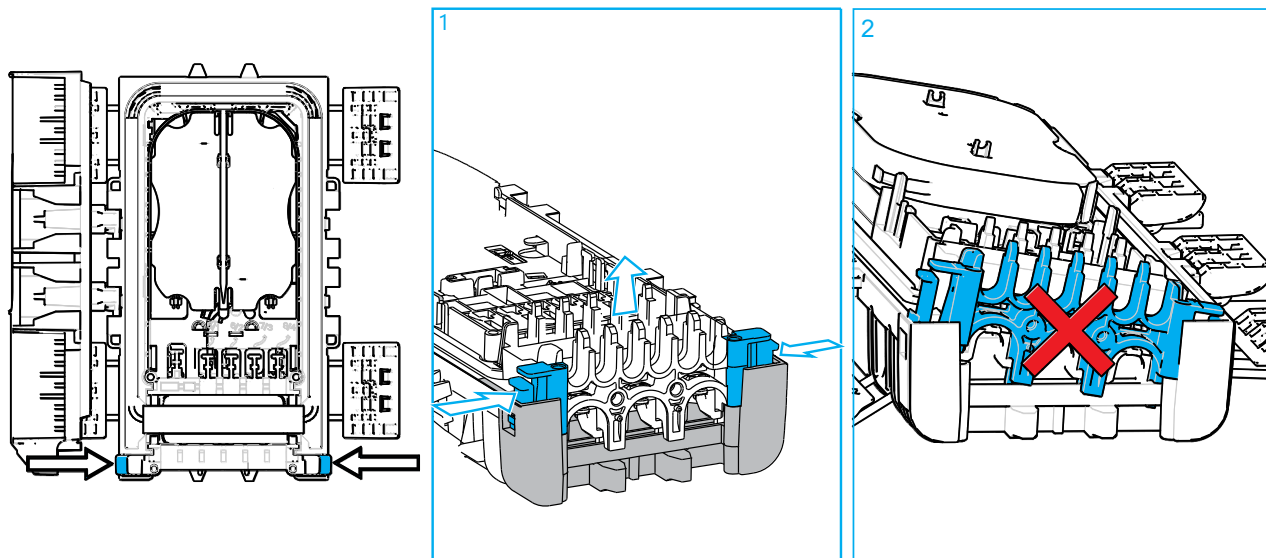

- 1 Push on the two tabs situated under the Octopus™ gel seal to release the organizer.
- 2 To remove the organizer, it is important to lift both sides simultaneously to avoid damaging it.

## 7 Install the Octopus™ gel blocks

Octopus™ gel block must be installed in the cover, in the base.

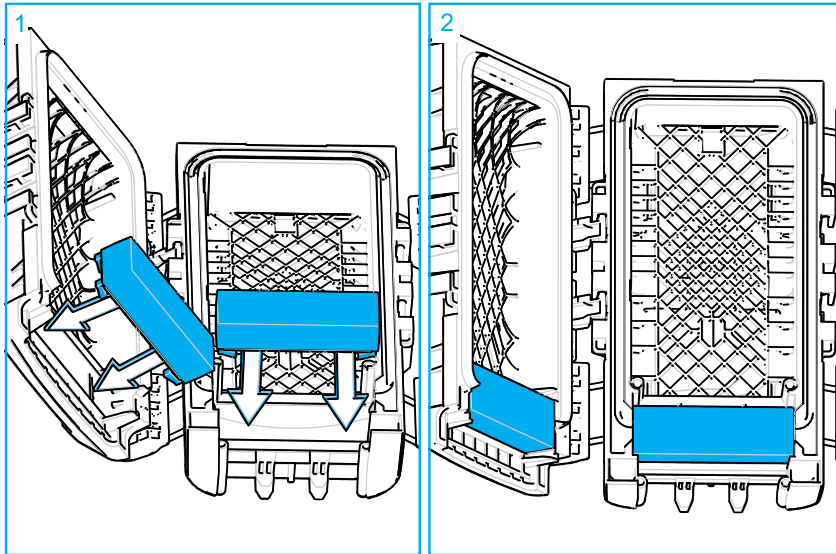

- 1 Install the Octopus™ gel blocks with the plastic support of the gel block facing downwards. Push the gel blocks on the ends into its cavity and push it in its cavity as far as possible.
- 2 Now the Octopus™ gel blocks are correctly installed.



## 8 Feeder cable

### 8.1 Using the feeder strain relief bracket

#### 8.1.1 Feeder cable preparation

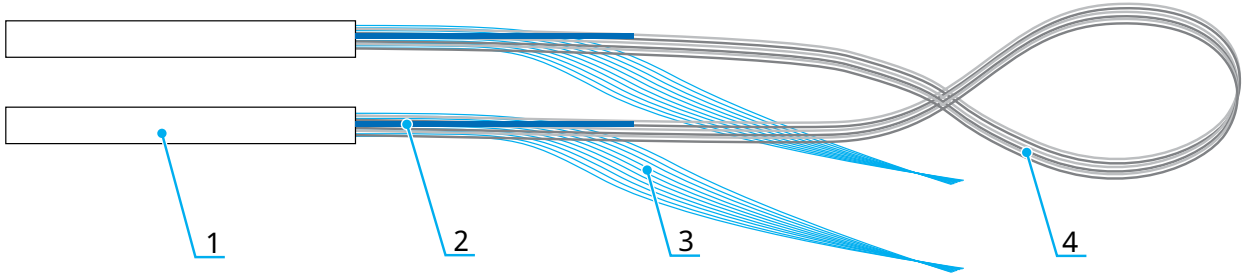

N.º	Description	Preparation
1	Jacket	<b>End cut</b> - Subunit cut at the jacket end. • Make a window cut of: 81 ±5 cm / 32 ±2 Inches.
		<b>Mid cut</b> - Subunit cut in the middle. • Make a window cut of: 162 ±5 cm / 64 ±2 Inches.
		<b>Cable end</b> • Remove the jacket over a distance of: 81 ±5 cm / 32 ±2 Inches.
2	Rigid Strength members	Leave 45 ±0,5 mm / 1.77 ±0.02 Inches (or verify with bracket).
3	Aramid yarn	Cut the aramid yarn to length to 15 ±1cm / 6 ±0.39 Inches. Limit the amount of aramid yarn.
4	Subunits	Clean the subunits, remove all grease.

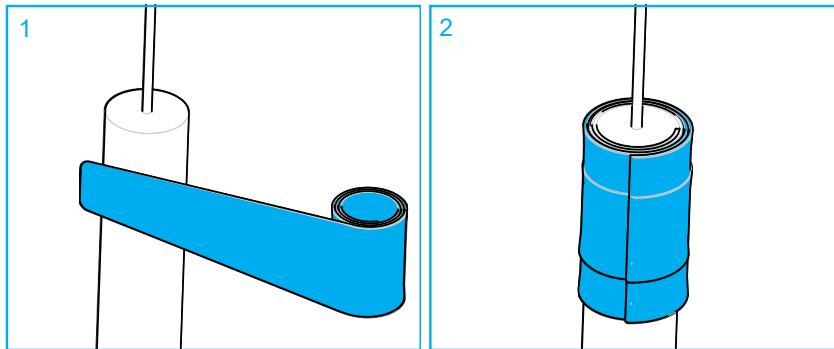

- 1 If the cable diameter is smaller than 9 mm / 0.35 Inches or if the jacket is a thin jacket, add 5 wraps of silicone tape.
- 2 Stretch the tape minimum 50% while wrapping the tape around the cable. Make sure the tape is wrapped where the hose clamp will be positioned.

## 8.1.2 Install feeder cable on feeder strain relief bracket

Feeder cables will typically be installed one end right (F1 - feeder in) and one end left (F2 - feeder out).

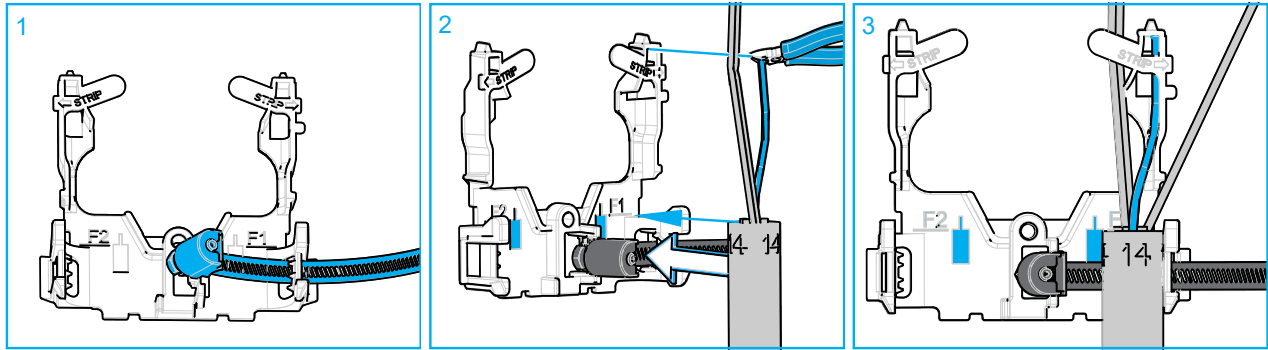

- 1 Open the hose clamp and place it on the bracket with the hose clamp band through the slot.
- 2 Position the cable on the bracket with the jacket end aligned with the indicated line on the bracket as shown. Verify the length of the strength member and cut to length.
- 3 Select the subunits that will be used for splicing to the drops. Keep them aside. Route the unused subunits along the center of the bracket and place the strength member in place. If the cable doesn't contain aramid yarn, proceed with step 6.

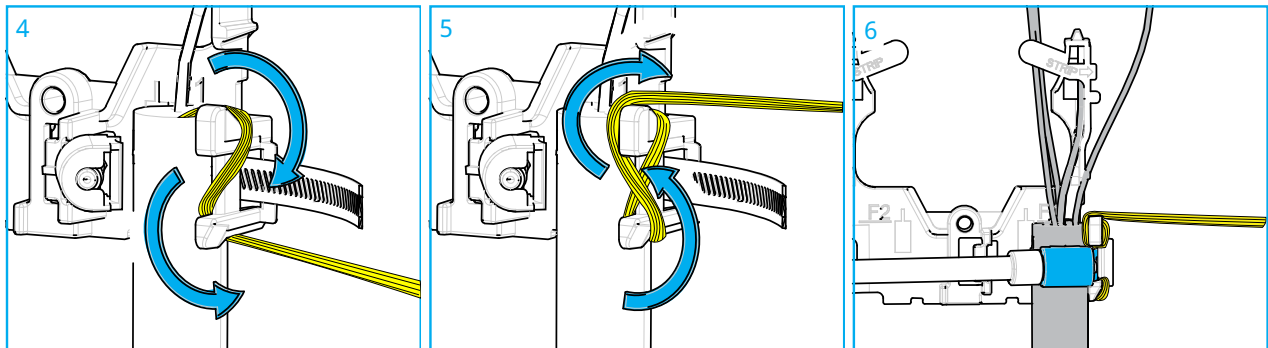

**Note:** Make sure the aramid yarn is always tensioned when installing.

- 4 Guide the aramid yarn under the top hook to the right side of the bracket. Make an S-turn to the left side of the lower hook.
- 5 Turn the aramid yarn under the bottom hook to the right side of the bracket and guide it along to the left side of the top hook. The aramid yarn will cross between the two hooks.
- 6 Close the hose clamp and secure with an appropriate tool.

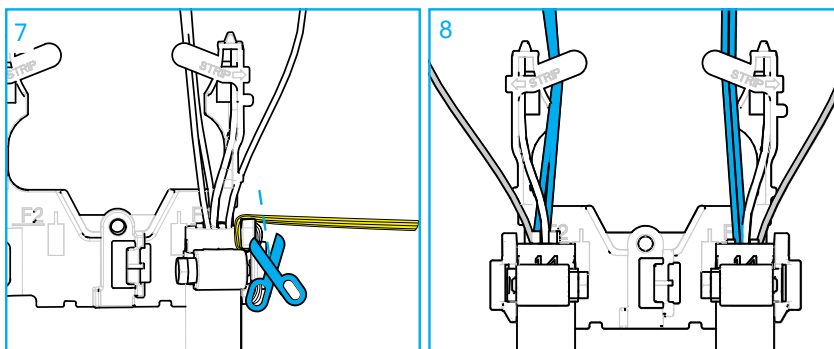

- 7 Cut the excess of the aramid yarn.
- 8 Install the other side in the same way and guide the unused subunits under the lips.

## 8.1.3 Feeder cable installation

### 8.1.3.1 Port reducers

Port reducers are installed above and below the Octopus™ gel seal. Depending on the cable diameter, the port reducers should remain or need to be removed. The port reducer in the middle port should always remain in place. If the cable diameter is **less than or equal to 10 mm / 0.39 Inches**: keep the two port reducers in place. In this case, continue with the next section. Steps below are not applicable.

If the cable diameter is **more than 10 mm / 0.39 Inches**: remove the two port reducers of the respective port. In this case, continue with the steps below.

If the cable is not positioned freely, remove the two port reducers.

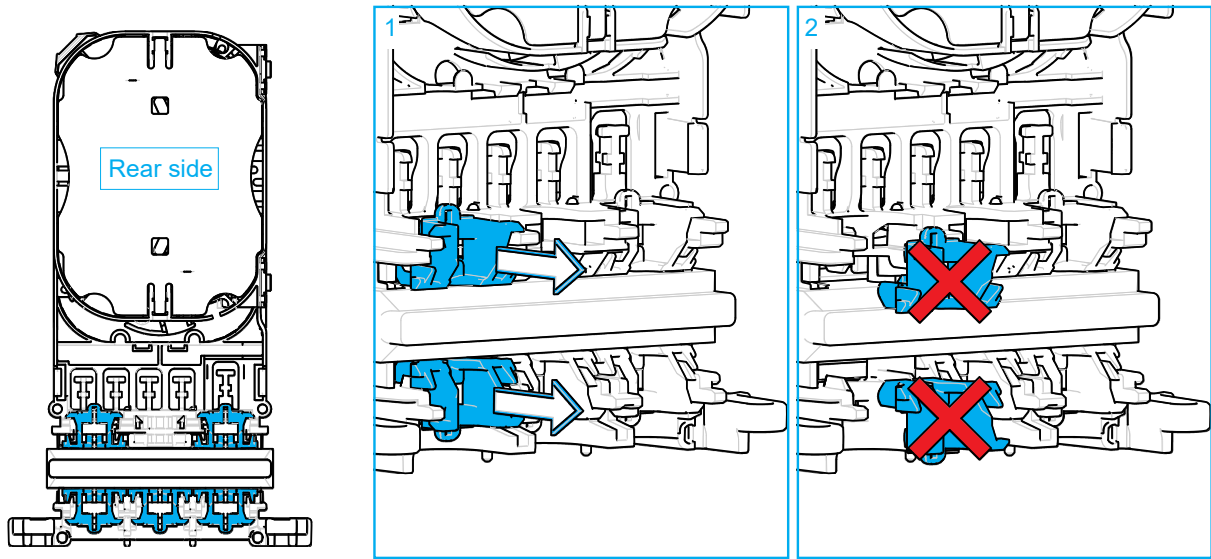

- 1 Lift up the two port reducers at both sides of the Octopus™ gel seal (no tools needed).
- 2 Remove the both parts of the respective port. (In total 4 parts for a looped feeder cable.)

### 8.1.3.2 Install feeder cable bracket

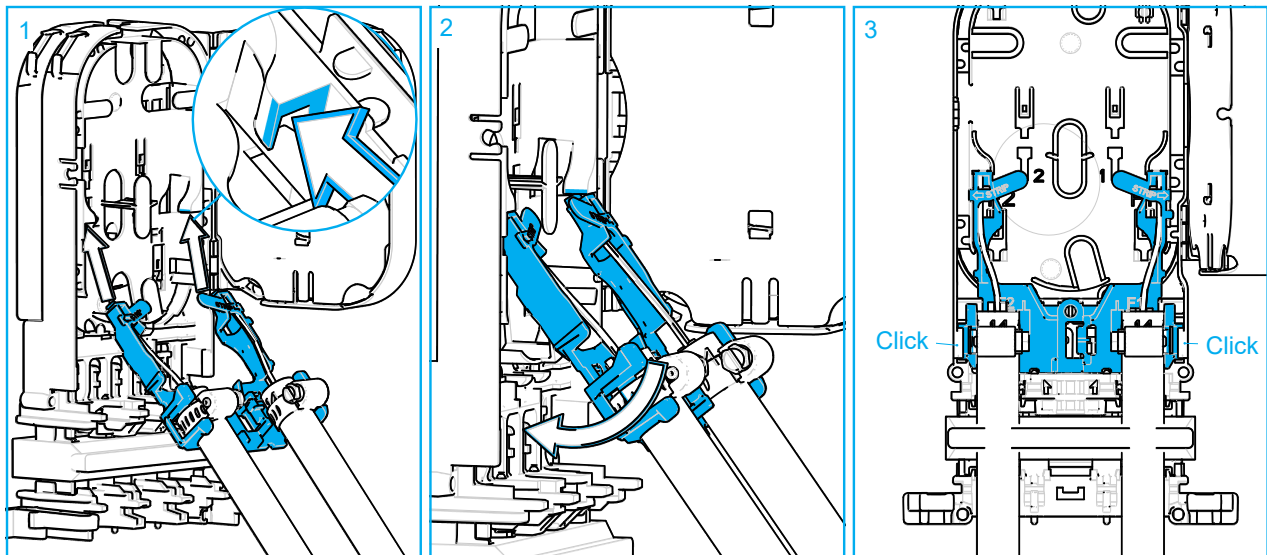

- 1 Insert the 2 pins on the top of the bracket into the 2 holes on the tray.
- 2 Push the assembly inside the tray.
- 3 The assembly is secured when you hear a click on both sides.

## 8.2 Using the cable retention NVX-CR-DU-SL-NN: Mini dual cable

The mini dual bracket can be used to install one or two feeder cables with a diameter  $\leq 6,2$  mm / 0.25 inches at the F1 position on the feeder side. See the installation instruction TC-1529-IP - NVX-CR-DU-SL-NN: Cable retention: Mini dual cable for the cable preparation. Follow the next steps to install the bracket.

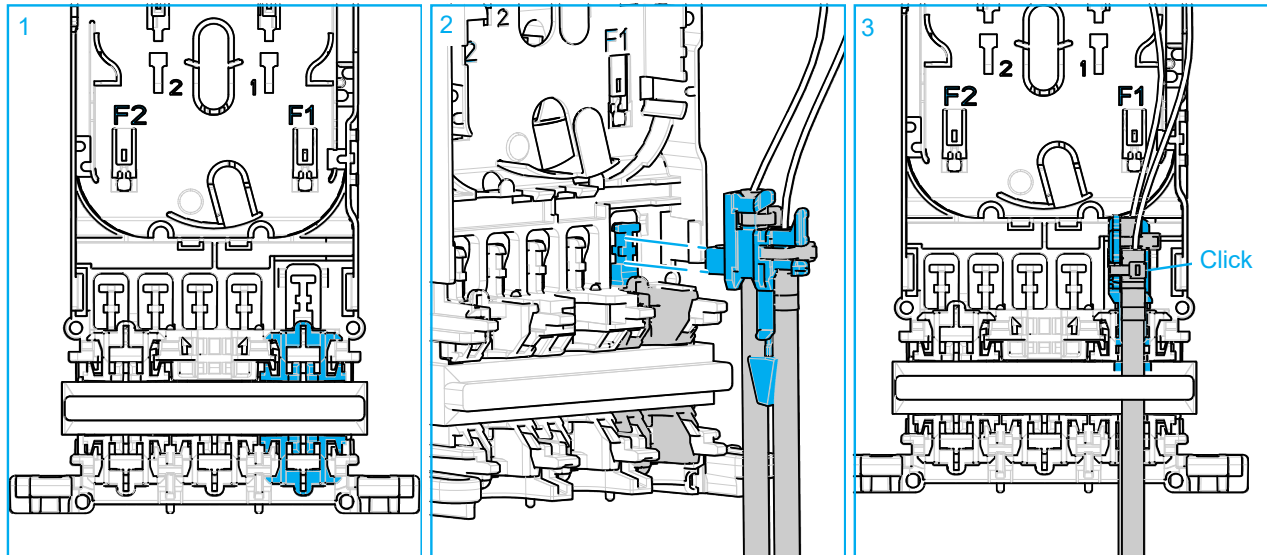

- 1 Make sure the port reducers of the F1 feeder port are installed.
- 2 Align the two hooks on the rear side of the carrier with the t-shape.
- 3 Push the carrier so that the hooks on the rear slide over the t-shape. A clicking sound is observed.

## 8.3 Route feeder fibers to storage

### 8.3.1 Route subunits to loop storage basket

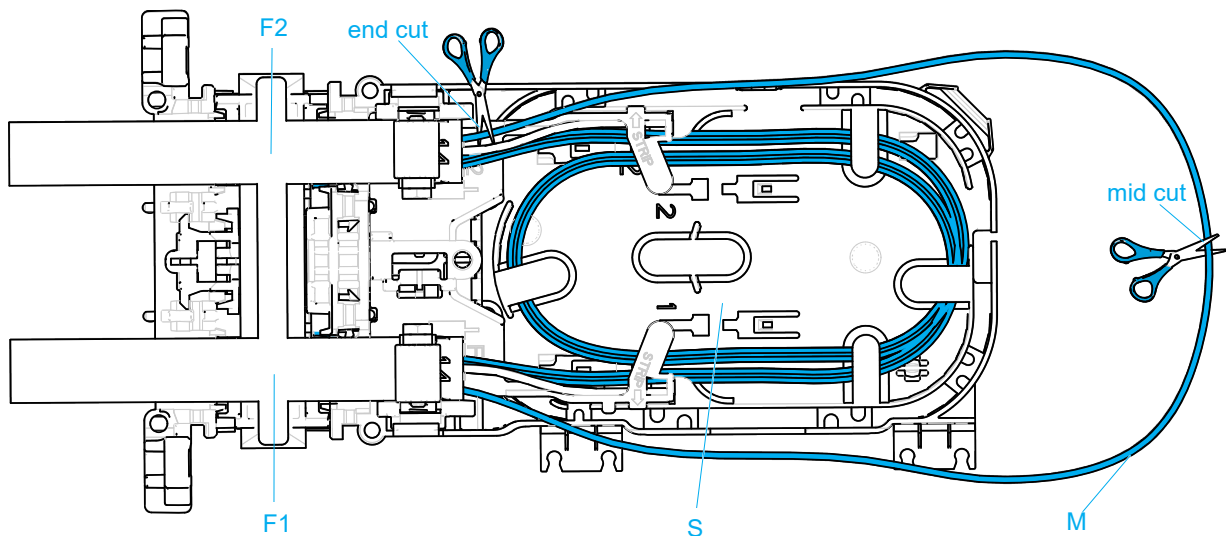

- F1: Entry
- F2: Exit
- S= Storage area
- mid cut: cut the subunit in the middle
- end cut: cut the subunit at the jacket end at exit side (F2)

- 1 Select the subunits that will be used for splicing to the drop cables. Keep them separate.
- 2 Make loops of the subunits that will not be used and store it in the loop storage basket.

3 The different options for the selected subunits are:

- Endcut: cut the subunit at the jacket end of the exit (F2) and route the subunit to the stripping point at the front side.
- Midcut: cut the subunit in the middle of the unit and store the end that will not be used (F2) in the loop storage basket. Route the other end (F1) to the stripping point at the front side.

### 8.3.2 Route feeder fibers to the front splice tray

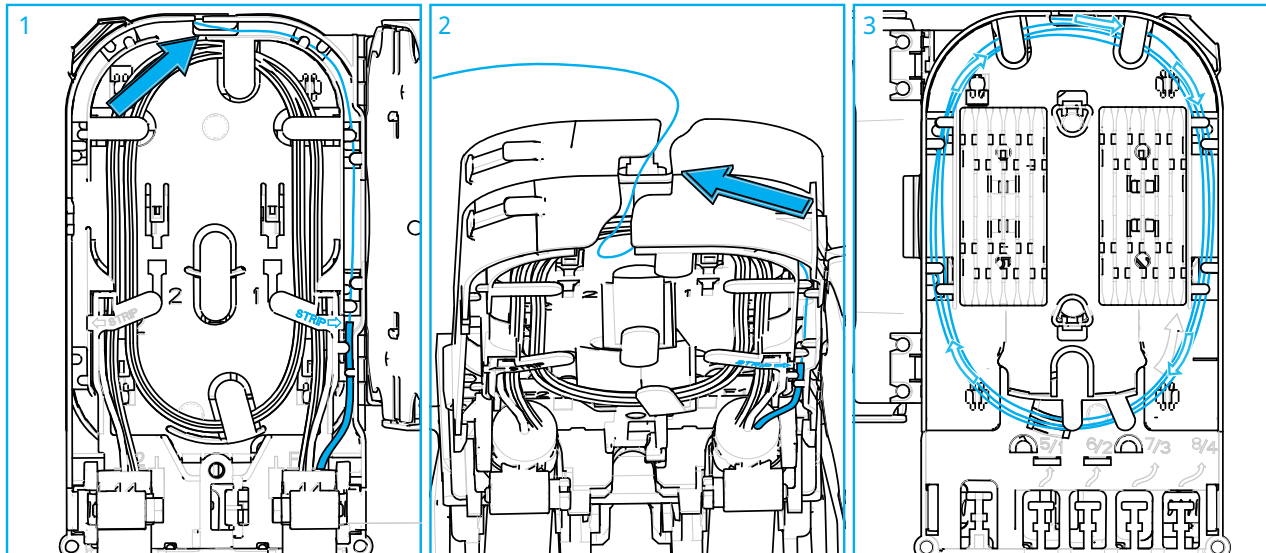

1 The arrow on the feeder bracket indicates the stripping point. Mark the subunit at the stripping point and remove the jacket per local practice. Route the subunits to the top of the tray.

 **Note:** Make sure the fibers are routed underneath the lips.

2 Use the transportation zone at the top of the tray to guide the subunits to the front splice tray.

3 Store the subunit on the splice tray underneath the lips.

### 8.3.3 Route feeder fibers to the storage zone of the hinged tray

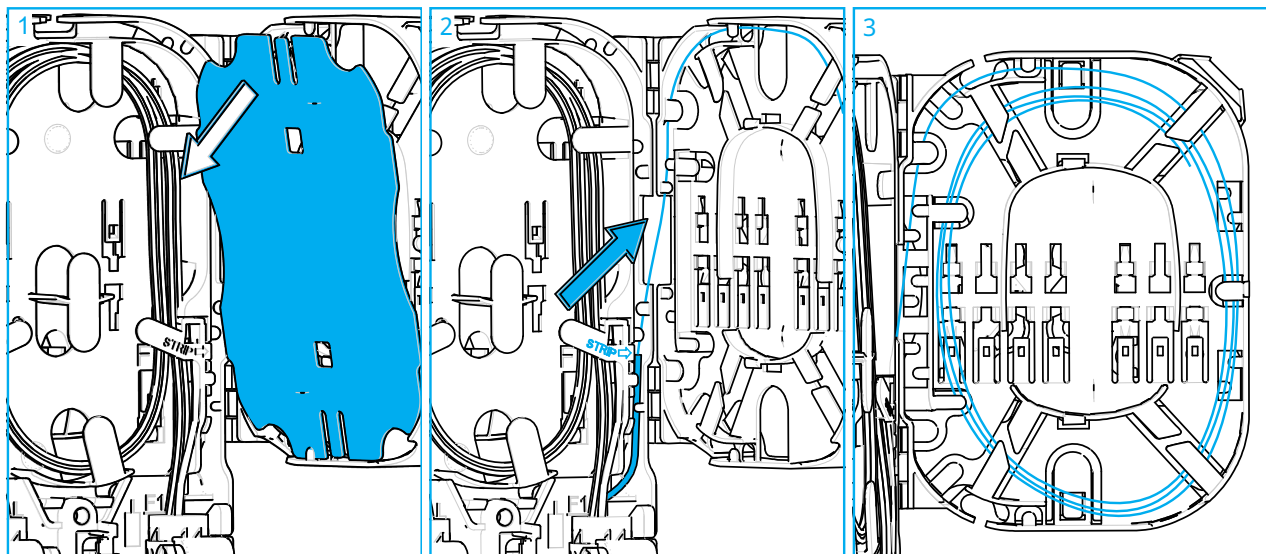

1 Remove the cover at the back of the hinged tray.

2 The arrow on the feeder bracket indicates the stripping point. Mark the subunit at the stripping point and remove the jacket per local practice. Route the subunits to the back of the hinged tray. Make sure the fibers are routed underneath the lips

3 Store the subunit on the back of the hinged tray and put the cover back in position.

### 8.3.4 Route feeder fibers to the splice zone of the hinged tray

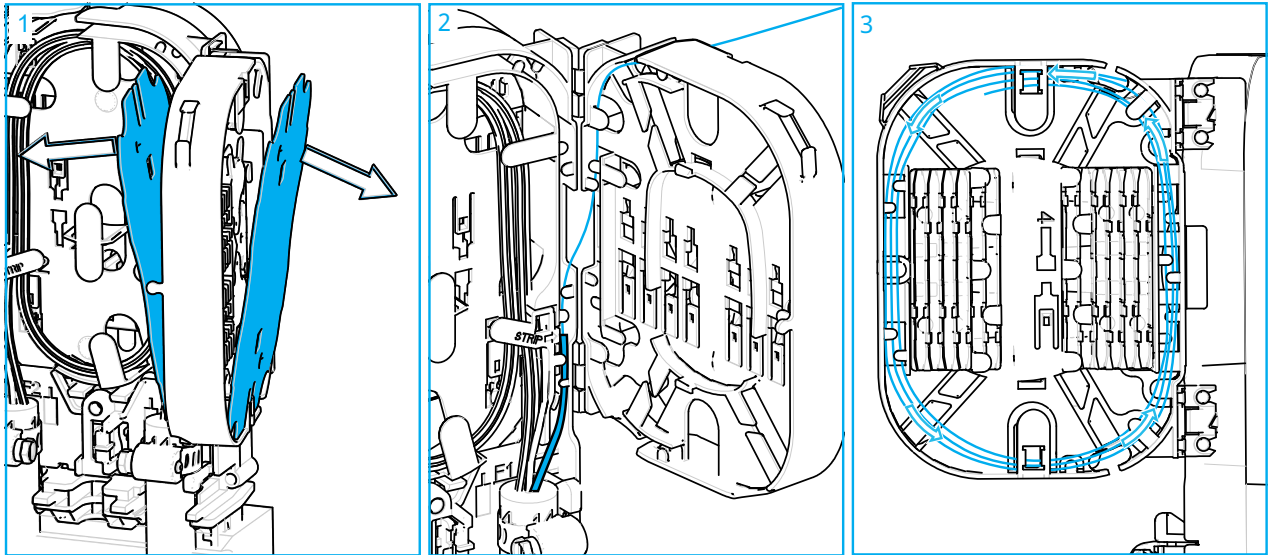

- 1 Remove the front and back cover of the hinged tray.
- 2 The arrow on the feeder bracket indicates the stripping point. Mark the subunit at the stripping point and remove the jacket per local practice. Route the subunits to the back of the hinged tray. Use the split at the top of the hinged tray to route to the other side of the tray.
- 3 Store the subunits in the splice tray. Replace the front and back cover of the hinged tray.

## 9 Re-install organizer

### 9.1 Re-install organizer

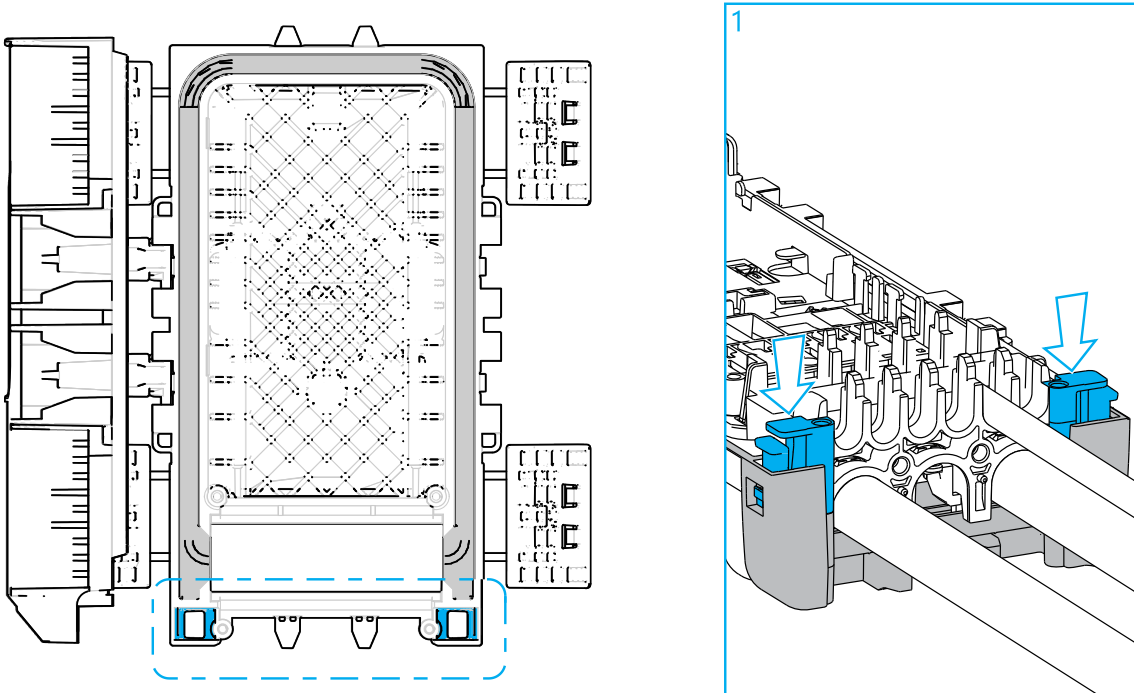

- 1 Position the organizer in the closure with the front side (drop side) facing on top. Push firmly on the snap features to lock the organizer in the closure. When a click sound is noticed, the organizer is properly locked.

## 10 Close the closure

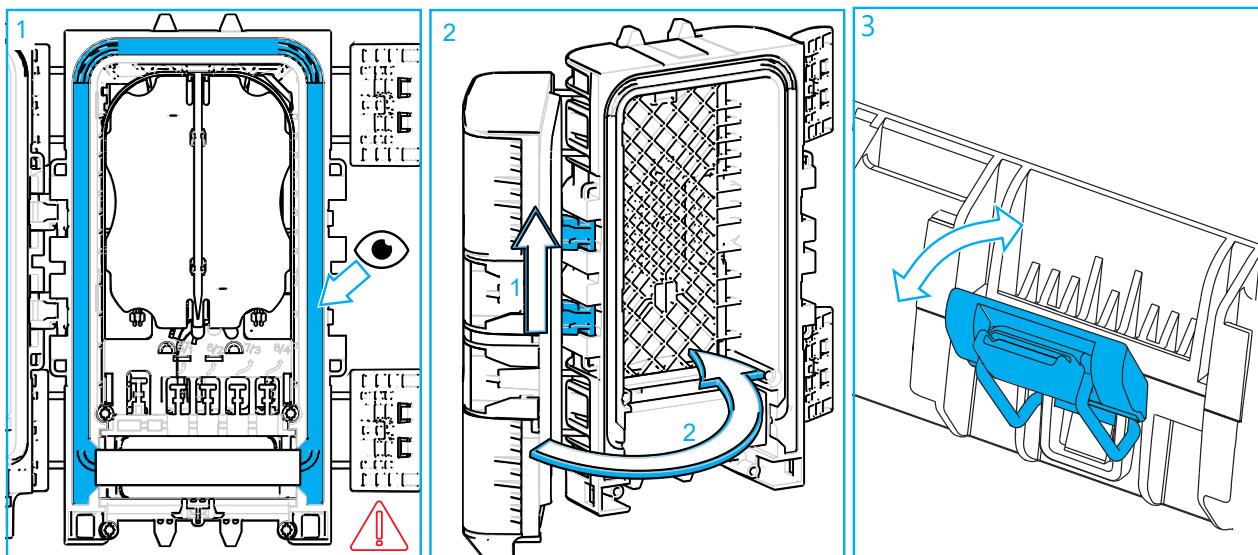

- 1 Inspect the long seal. The seal should be clean and dust free. Verify the long seal is correctly seated within the closure cavity.
  - 2 Position the cover back onto the base. Figure 2 shows the cover installed with the hinges on the left side.
-  **Note:** First lift the cover slightly up to release the cover from its lock position, then rotate it towards the base.
- 3 Close the latches.

## 11 Mount the closure

### 11.1 Using the Mobra

#### 11.1.1 Kit contents mobra

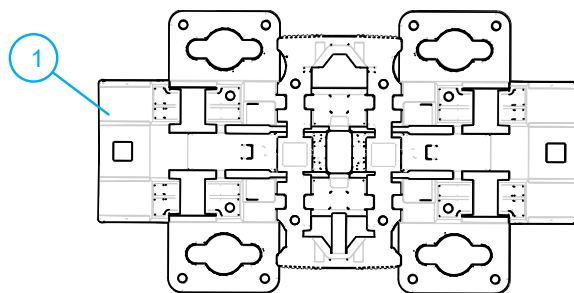

N°	Description	Qty
1	Universal Mounting Bracket	1

-  **Note:** Mounting hardware (such as screws, plugs, washers) should be selected according to intended mounting surface (not included in the kit).

### 11.1.2 Mount the mobra

Depending on the use, there are several options for mounting the mobra.

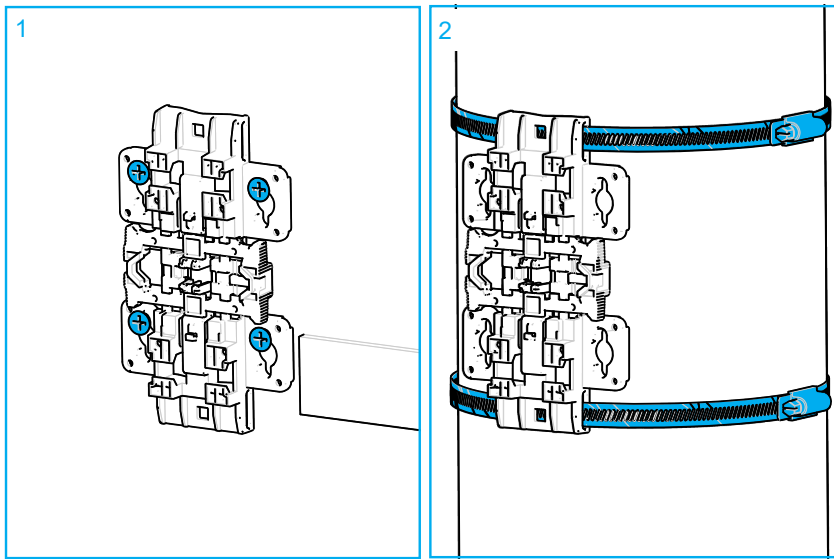

- 1 Mounting with 4 screws.
- 2 Mounting with straps.

### 11.1.3 Install/uninstall the mobra

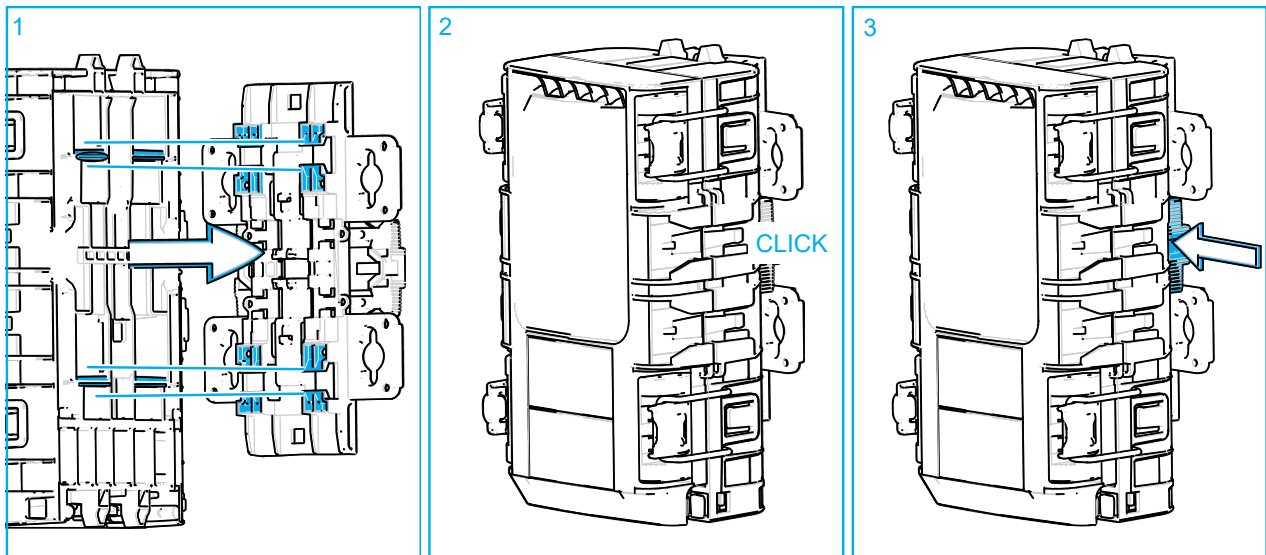

- 1 Install the enclosure on the mobra.
- 2 When a click sound is noticed, the enclosure is properly locked.
- 3 Push the release button (left or right) on the mobra to release the enclosure.



## 11.2 Using the mounting tabs

### 11.2.1 Kit contents

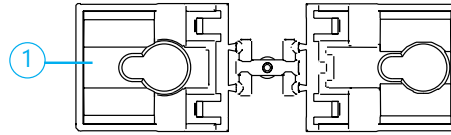

N°	Description	Qty
1	Mounting bracket	1

 **Note:** Mounting hardware (such as screws, plugs, washers) should be selected according to intended mounting surface (not included in the kit).

### 11.2.2 Mounting tabs installation

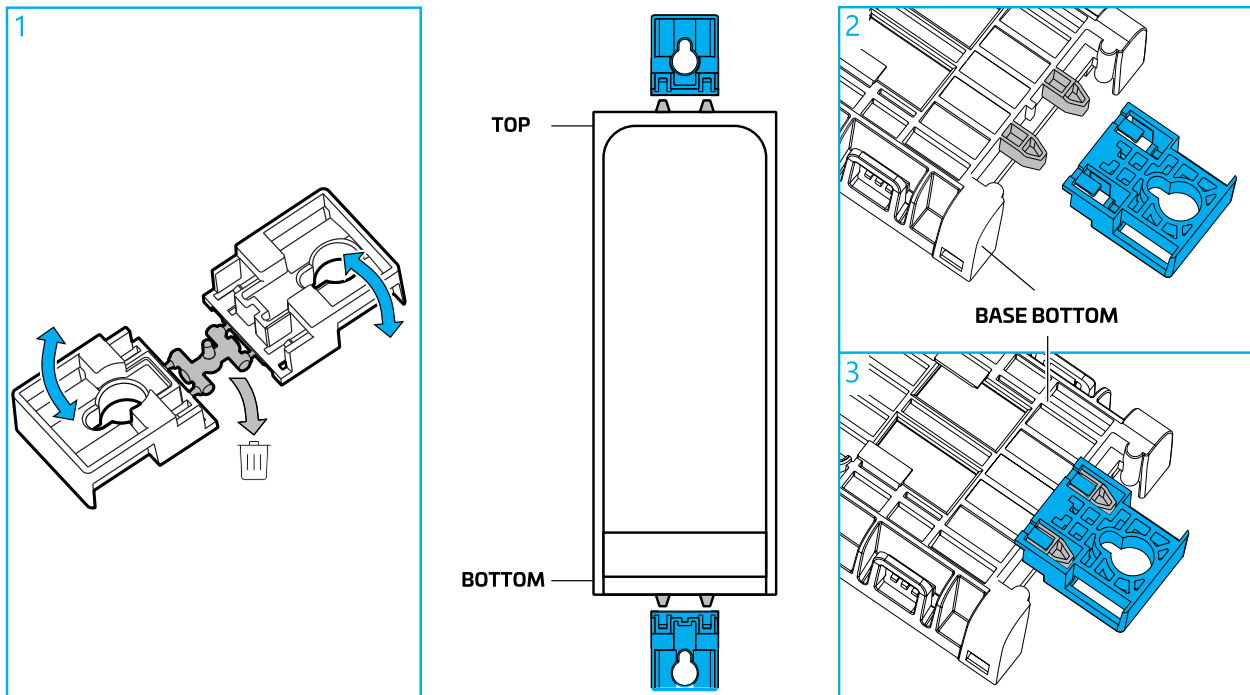

- 1 Break off the two mounting tabs.
- 2 Note: the two tabs are not identical. Make sure to mount the tabs in the correct position. Small hole facing upwards.
- 3 Mount the tabs on the base at both sides (top and bottom).

### 11.2.3

### Wall mounting

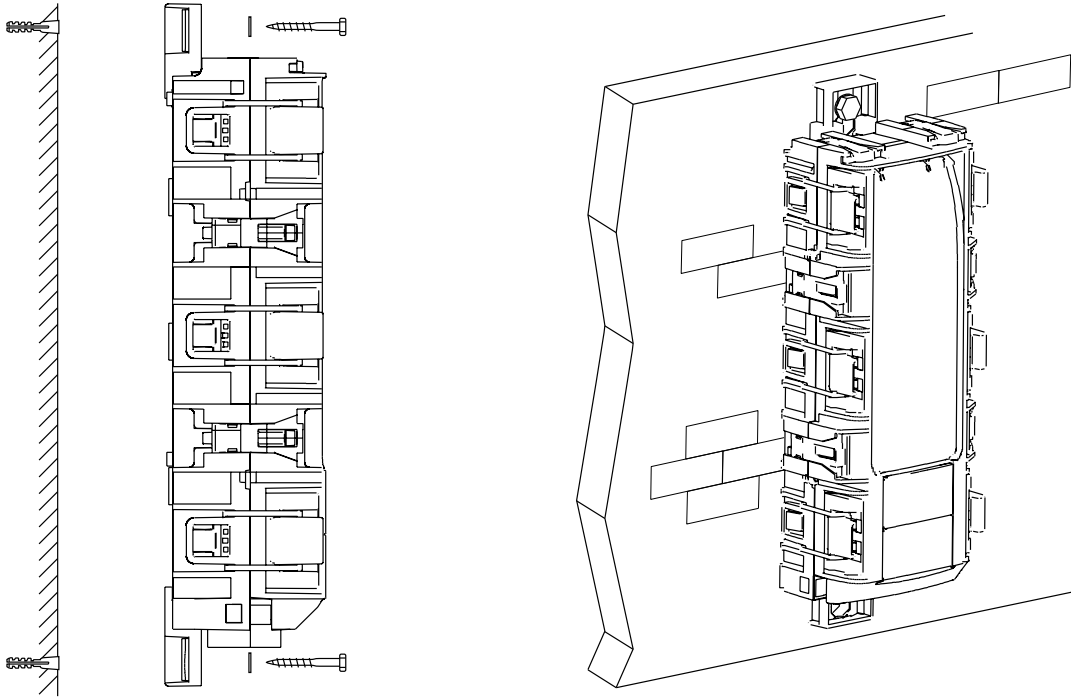

Using the mounting tabs as a template, mark the mounting screw locations on the selected surface for the installation. Install wall plugs first, then position the closure with the mounting tabs against the surface. Continue with the washers and the screws to secure the closure onto the surface.

## **12 Disclaimer**

All trademarks identified by ® are registered trademarks in the US and may be registered in other countries. All third party product names, trademarks and registered trademarks are property of their respective owners.

This product may be covered by one or more U.S. patents or their foreign equivalents. For patents, see [www.cs-pat.com](http://www.cs-pat.com).

This document is not intended to modify or supplement any specifications or warranties relating to CommScope products or services.

## **13 Contact information**

Visit our website or contact your local CommScope representative for more information. [www.commscope.com](http://www.commscope.com)

For technical assistance, customer service, or to report any missing/damaged parts, visit us at:

<http://www.commscope.com/SupportCenter>

## NOVUX™ Fiber Optic System CC 40 - Patch Application

### About this manual

This installation instructions document describes the installation steps of the **patch application** of the Compact Closure 40 series. Installation steps in this document are limited to: splicing input of the connectors to the feeder fibers, patching SC cables and patching LC cables.

Installation steps of the feeder cables are explained in manual TC-1520-IP: CC 40 Basic Instructions.

The document starts with providing an overview of the tools required to perform the installation. Also warnings and cautions are indicated, which should be observed before starting the product installation.

Images in this manual are for reference only and are subject to change.

### General product information

	Quantity drops	installation method drops
SC/APC or SC/UPC	up to 4	Pre-connectorized with and without transition, Xpress drop
LC/APC or LC/UPC	up to 8	Pre-connectorized with and without transition, Xpress drop

### Overview organizer

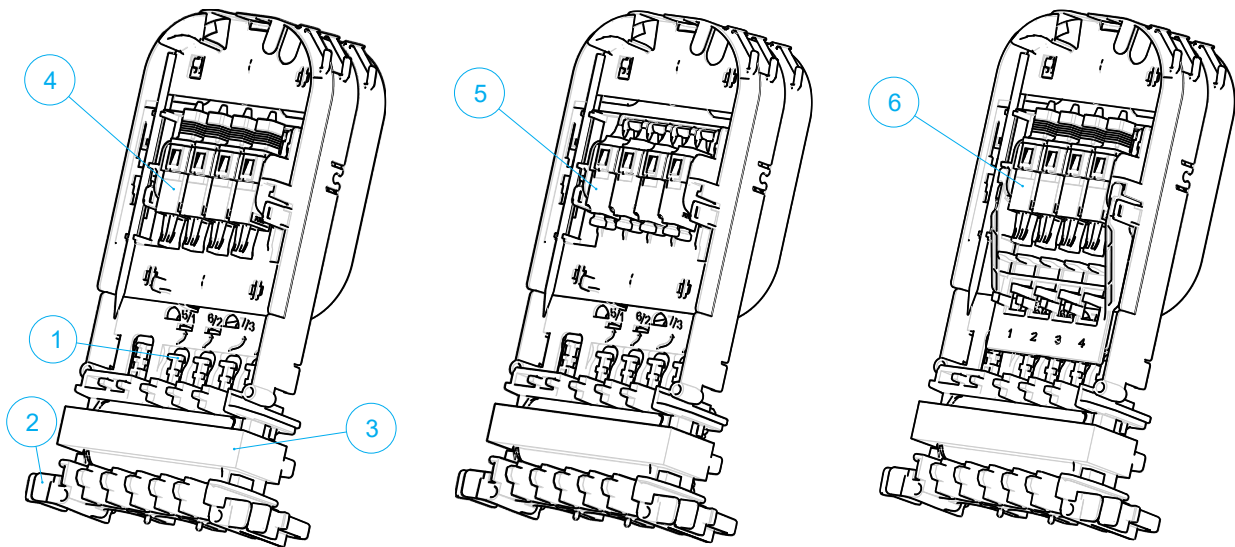

- 1 Drop cable strain relief T-shapes
- 2 Locking features
- 3 Octopus™ gel seal
- 4 SC adapters
- 5 LC adapters
- 6 SC Xpress drop

# Contents

<b>1 Abbreviations.....</b>	<b>3</b>	<b>5 Pre-connectorized cable.....</b>	<b>5</b>
<b>2 Tools.....</b>	<b>3</b>	5.1 Install SC-connectorized drop cable.....	5
<b>3 Warnings and Cautions.....</b>	<b>3</b>	5.2 Install LC-connectorized cable.....	6
<b>4 Splice feeder to input connector.....</b>	<b>3</b>	5.3 Install SC/LC Xpress drop.....	7
4.1 Splice feeder direct to input connector.....	4	<b>6 Trade-marks.....</b>	<b>8</b>
4.2 Splice feeder to factory installed splitter.....	4	<b>7 Contact information.....</b>	<b>8</b>

# 1 Abbreviations

CC: Compact Closure

# 2 Tools

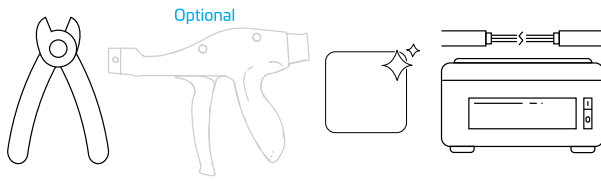

# 3 Warnings and Cautions

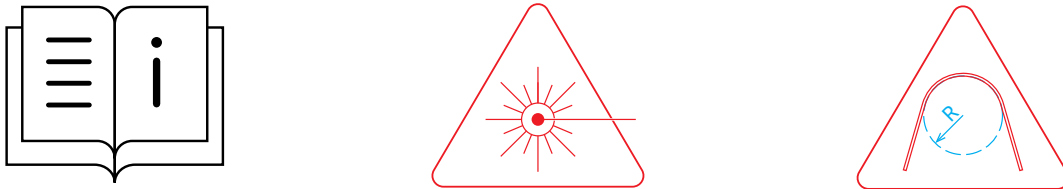

- Follow the installation instruction steps to ensure the performance of the closure. It is necessary to take precautions and keep the working space clean to protect the closure sealing materials and splices.
- Exposure to laser radiation can seriously damage the retina of the eye. Do not look into the ends of any optical fiber. Do not assume the laser power is turned off or that the fiber is disconnected at the other end. Looking into the ends of any optical fiber is entirely at your own risk. A protective cap or hood **MUST** be immediately placed over any radiating adapter or optical fiber connector to avoid the potential of dangerous amounts of radiation exposure. This practice also prevents dirt particles from entering the connector and adapter.
- Fiber optic cables may be damaged if bent or curved to a radius that is less than the recommended minimum bend radius. Always observe the recommended bend radius limit when installing fiber optic cables, subunits and patch cords.

# 4 Splice feeder to input connector

Prepare and install the feeder cable as explained in the CC 40 base instructions TC-1520-IP. Route feeder fibers to the splice zone of the hinged tray.

## 4.1 Splice feeder direct to input connector

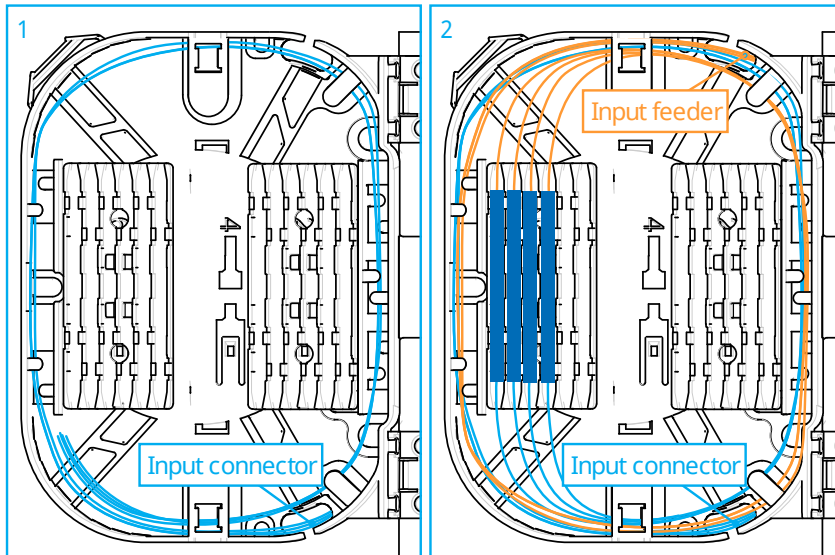

- 1 The inputs of the connectors patched at the front are routed to the splice side of the hinged tray as shown in image above. The 250 $\mu$ m fiber is already prepared.
- 2 Splice the input of the connectors to the feeder fibers by making a fusion splice: make fusion splice per standard practice, store the splice protector in the splice protector holder and store over length in loops on the tray.

 **Note:** The fiber guidance pen can be used to position all the fibers underneath the lips. Make sure all fibers are properly positioned underneath the lips and avoid bulging of the fiber.

## 4.2 Splice feeder to factory installed splitter

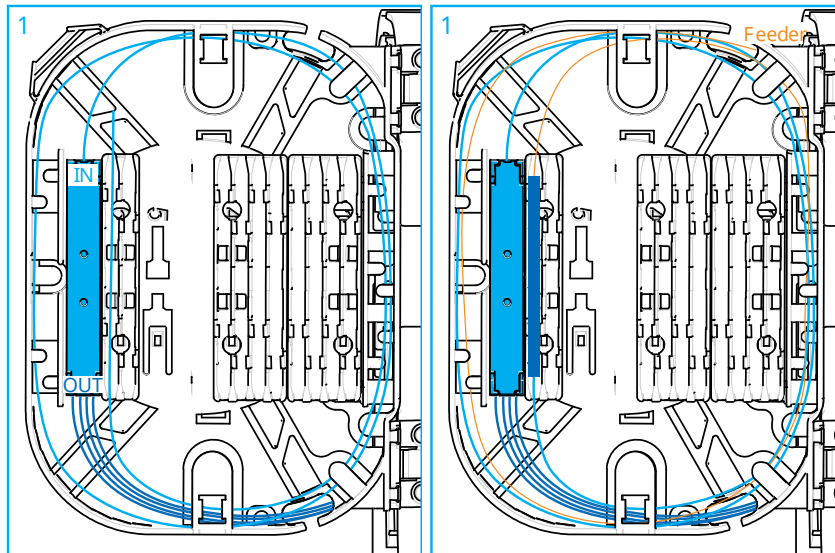

- 1 A splitter is installed on the hinged tray. The splitter outputs are already connected to the patch panel at the front side. The input of the splitter is a 900 $\mu$ m fiber that should be stripped and spliced to a feeder fiber.
- 2 Splice the input of the splitter to the feeder fiber by making a fusion splice: make fusion splice per standard practice, store the splice protector in the splice protector holder and store over length in loops on the tray.

 **Note:** The fiber guidance pen can be used to position all the fibers underneath the lips. Make sure all fibers are properly positioned underneath the lips and avoid bulging of the fiber.

## 5 Pre-connectorized cable

### 5.1 Install SC-connectorized drop cable

The separate cable retention kit TC-1529-IP (Cable retention: Mini dual cable) must be used to install the SC-connectorized cable in the CC 40 patch application.

 **Note:** The drop ports are designated with the numbers 5/1, 6/2, 7/3 and 8/4. (4 SC connections in total)

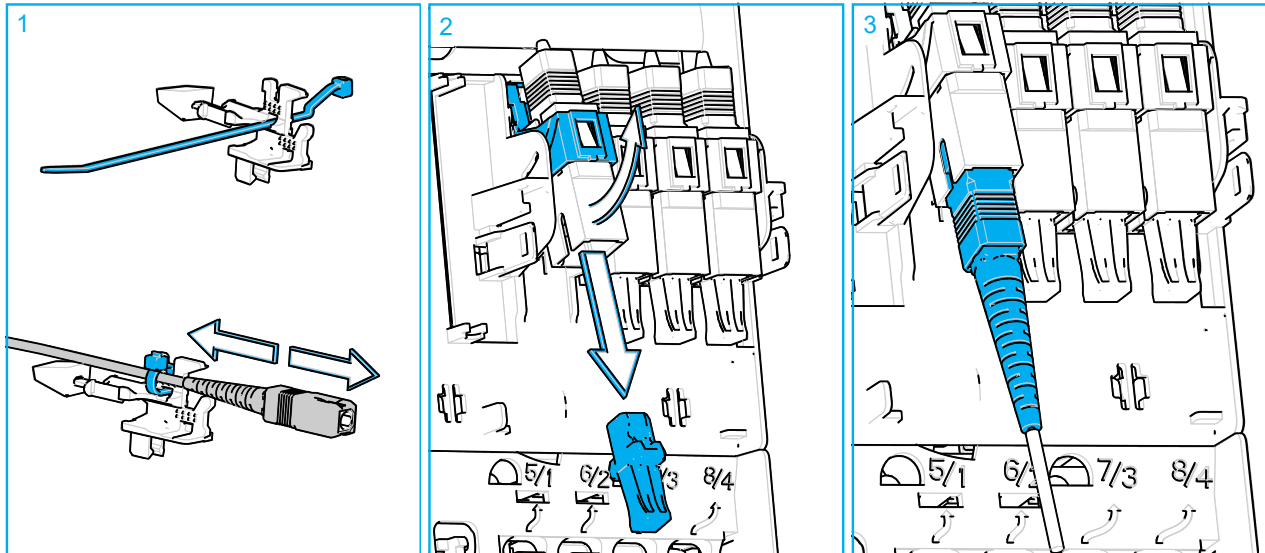

- 1 Install a cable tie in the top slot at the top position of the carrier. Make sure the heads are oriented correctly. Install the pre-connectorized cable and fasten the cable ties but don't tighten. The cable should move fluently up and down.
- 2 Swing the adapter port upwards and remove the dust caps of both connector and adapter of the selected port. Clean the connector and adapter per standard practice.
- 3 Position the connector in the correct orientation (rib facing as shown in figure above). Connect the connector to the assigned port. A clicking sound is observed when the connector is properly seated.

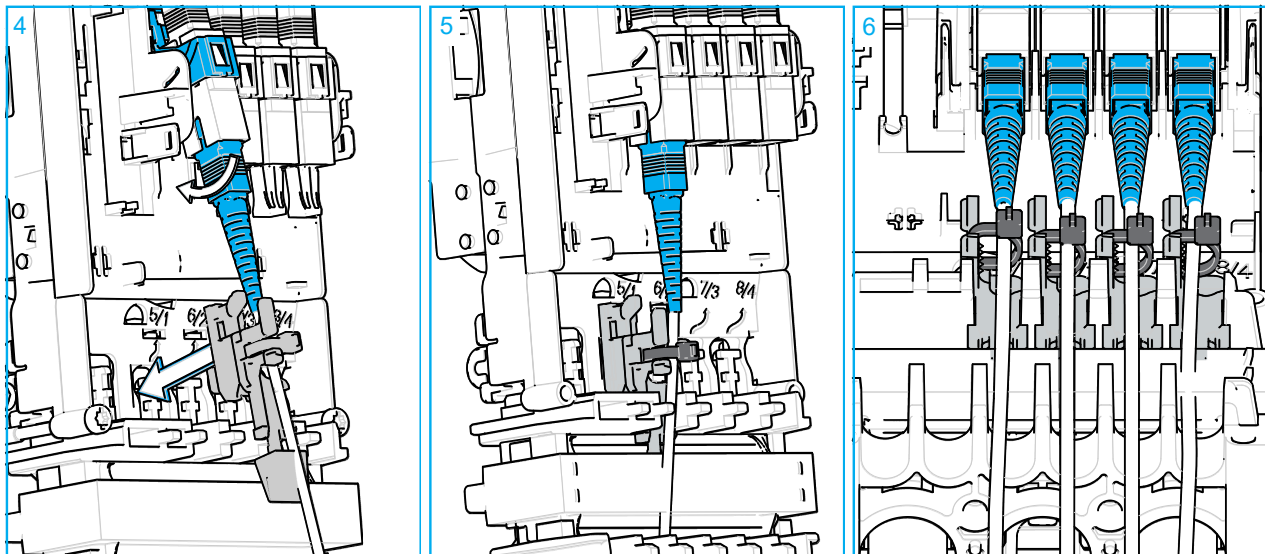

- 4 Slide the carrier with the cable ties over the cables up to the height of the t-shape. Swing the adapter port with cable back in its original position.
- 5 Punch the carrier in the t-shape.
- 6 Repeat the previous steps to install the other drop cables. Each cable should be routed to a separate entrance port. Press each cable between the two ribs of the entrance port below the adapter port.



## 5.2 Install LC-connectorized cable

The separate cable retention kit TC-1529-IP (Cable retention: Mini dual cable) must be used to install the LC-connectorized cable in the CC 40 patch application.

**Note:** The drop ports are designated with the numbers 5/1, 6/2, 7/3 and 8/4 (two adapter per port, allowing to make 8 LC connections in total).

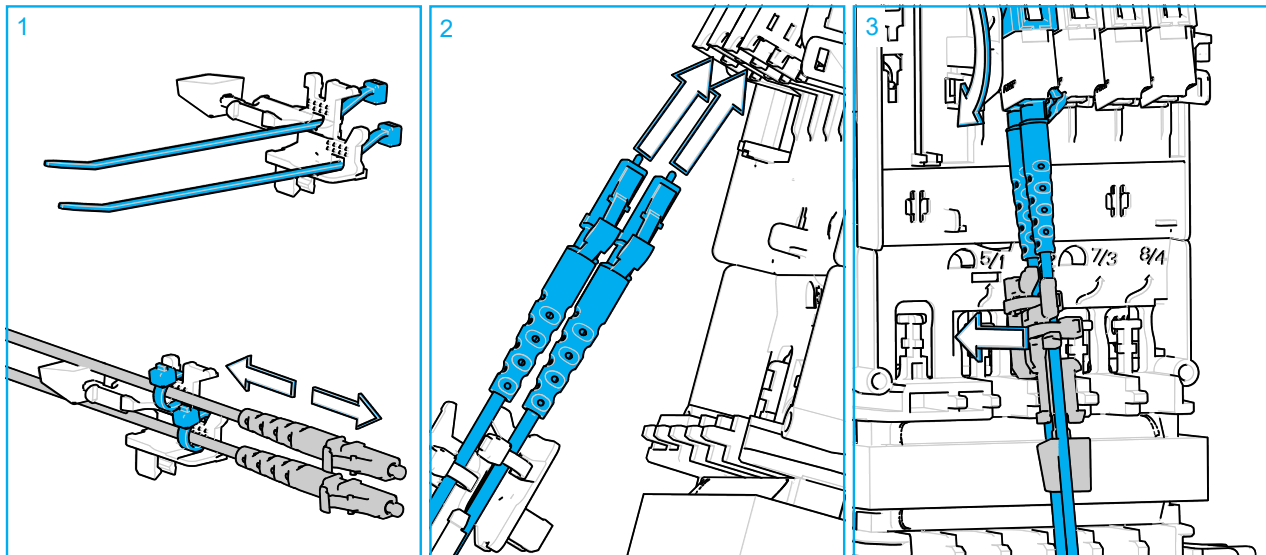

1 Install a cable tie in the slot of the carrier at the bottom position and one in the slot at the top position. Make sure the heads are oriented correctly. Install the pre-connectorized cable on each level and fasten the cable ties but don't tighten. The cable should move fluently up and down.

**Note:** If only one cable to be installed, select the top position.

- 2 Swing the adapter port upwards. Remove the dust caps of both connectors and adapters of the selected ports. Clean the connectors and adapters per standard practice. Position the connectors in the correct orientation. Connect the connectors to the assigned ports.
- 3 Slide the carrier with the cable ties over the cables up to the height of the t-shape. Swing the adapter port with cable back in its original position.

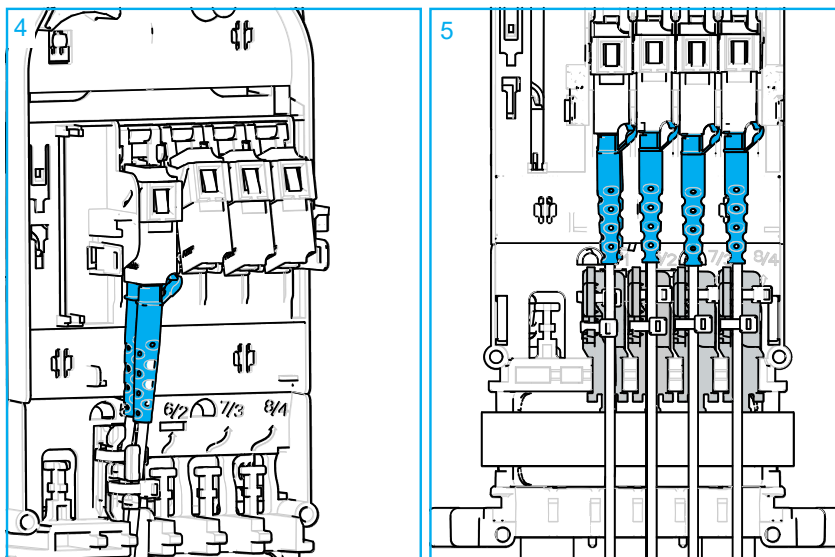

- 4 Punch the carrier in the t-shape.
- 5 Repeat the previous steps to install the other drop cables. Press the cables between the two ribs of the entrance port below the carrier.

## 5.3 Install SC/LC Xpress drop

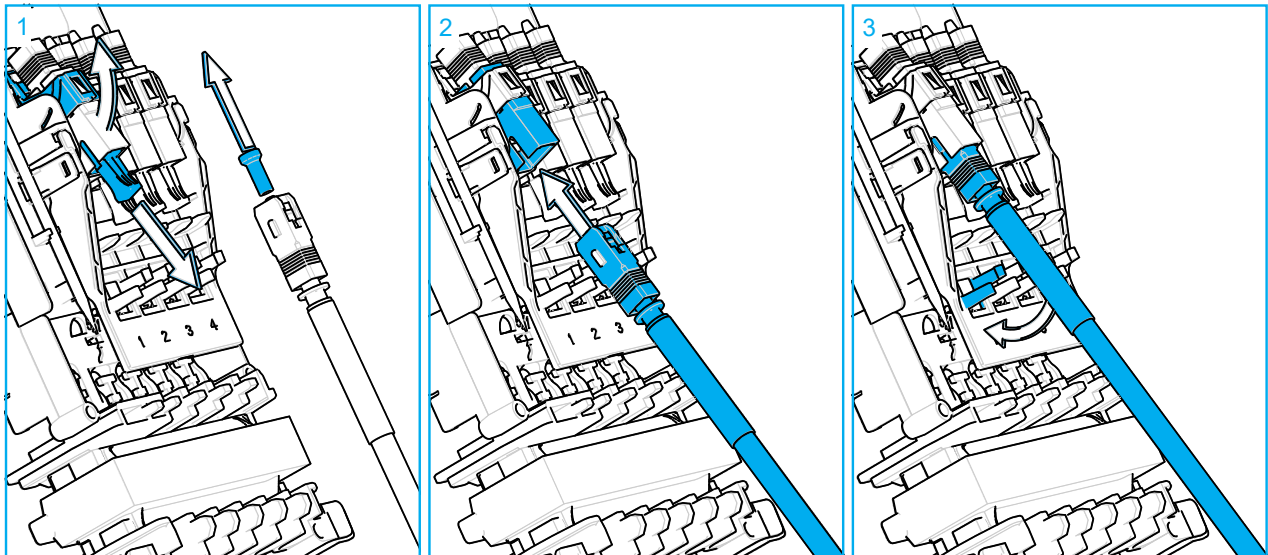

- 1 Remove dust caps of both the connector and the adapter port. Clean per standard practice. Swing the adapter port upwards.
- 2 Position the connector in the correct orientation. Connect the connectorized drop to its assigned port. A clicking sound is observed when the connector is properly seated.
- 3 Swing the adapter port with cable back in its original position.

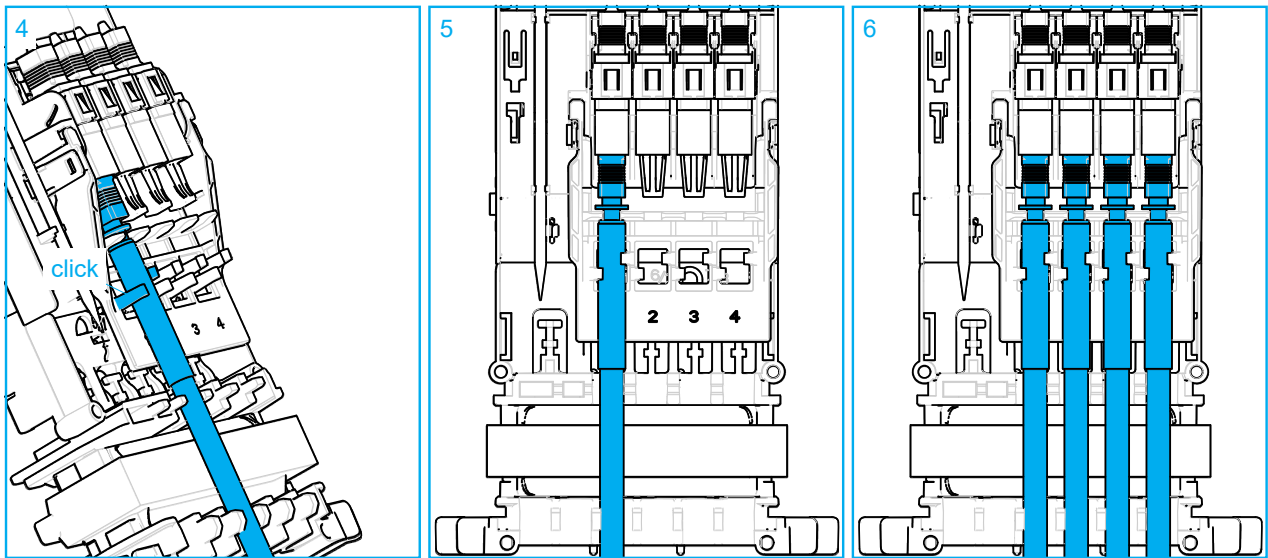

- 4 The metal ring just under the connector will click into the two snap hooks. The cable is hold between the two snap hooks positioned lower on the organizer.
- 5 First Xpres drop cable installed.
- 6 All Xpres drop cables installed.

## **6 Trade-marks**

All trademarks identified by ® are registered trademarks in the US and may be registered in other countries. All third party product names, trademarks and registered trademarks are property of their respective owners.

This document is for planning purposes only and is not intended to modify or supplement any specifications or warranties relating to CommScope products or services. CommScope is committed to the highest standards of business integrity and environmental sustainability, with a number of CommScope's facilities across the globe certified in accordance with international standards, including ISO 9001, TL 9000, and ISO 14001.

Further information regarding CommScope's commitment can be found at: <https://www.commscope.com/corporate-responsibility-and-sustainability>.

This product may be covered by one or more U.S. patents or their foreign equivalents. For patents, see [www.cs-pat.com](http://www.cs-pat.com)

## **7 Contact information**

Visit our website or contact your local CommScope representative for more information.

For technical assistance, customer service, or to report any missing/damaged parts, visit us at: <http://www.commscope.com/SupportCenter>